

**LaserPin**

# PUNCHING TOOLS

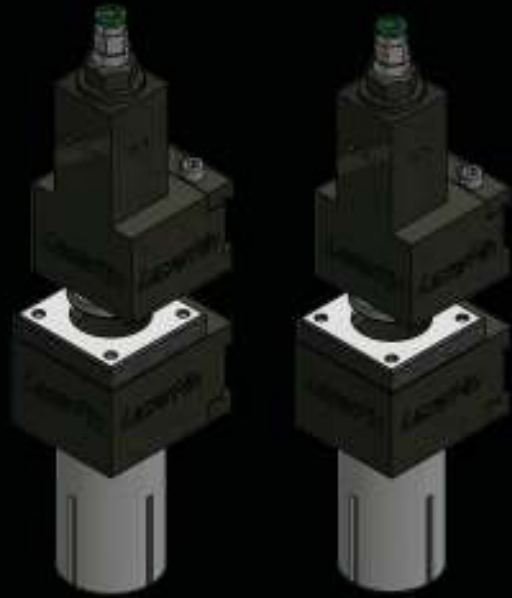

## Laserpin's Punching Tools last up to 5 times longer than our top competitors'

Laserpin constantly gives the uttermost care in supplying its customers with high quality components and equipment.

When it comes to Macro Perforation, the components which need replacement over time are the hammer and die of the punching unit tools.

The punching tools consist of an upper part (where the hammer is placed) and a lower part (with a die).

During the perforation process, the plastic film slides through hammer and die, which come together to create the hole, up to frequencies of 35 strokes per second.

This action deteriorates over time the edge of the hammer and the upper surface of the die.

Laserpin's tools have the great advantage of lasting on average 5 times longer than those of its top competitors.

Moreover, Laserpin's punching tools are interchangeable with some of the competitors' equipment.

This means that, by replacing the old tools with Laserpin's, the operating costs could be significantly reduced over the equipment's lifespan. This is for both circular and shaped holes.

The company provides an efficient spare parts service to guarantee a fast replacement in case of need. The tools are available in stock with the standard diameters from 2 mm to 16 mm.

**LaserPin**  
Perforation Equipment

LaserPin srl

Viale Europa 18/20 - Cologno Monzese (Milan) Italy

Phone +39-022547475

[www.laserpin.eu](http://www.laserpin.eu) - [info@laserpin.eu](mailto:info@laserpin.eu)

# PUNCHING TOOLS

Laserpin's spare parts for punching units are available for both circular and non circular shapes (i.e. Eurohole and Handle bag).

The standard diameter ranges from 2 mm to 16 mm.

Laserpin also produces punching tools of larger diameters and different needs:

A set ranging from 20 mm to 30 mm

A set ranging from 35 mm to 60 mm

The biggest set for agricultural needs up to 100 mm

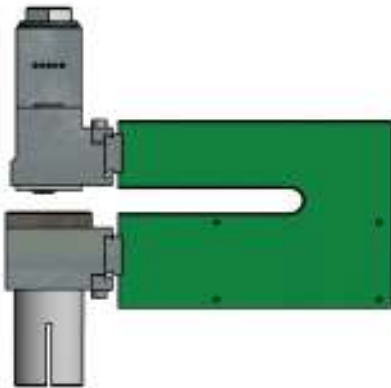
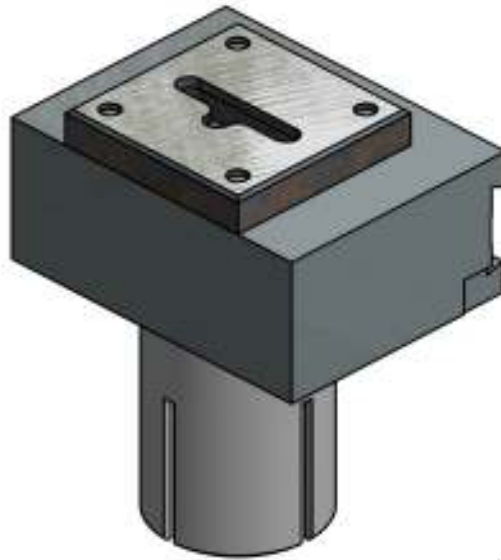

Maximum Frequency

35 Hz

Diameter of the Holes

2-100 mm

Maximum Material Thickness

800 microns

Maximum Speed

260 meters/minute

